

## Aviation Activities for the Classroom

Foreword . . . . .	2
--------------------	---

### Wind and Water

<b>Investigating the Weather</b> . . . . .	3
Dewpoint . . . . .	4
Frontal Movement . . . . .	6
Differential Pressure . . . . .	8
Funnel Demonstration . . . . .	9
Flying Beach Balls . . . . .	10
Air Pressure Demo . . . . .	12
Air Displaces Water . . . . .	13
Air Occupies Space and Has Body . . . . .	14
Using the Atmosphere to Lift Water . . . . .	15
Carbon Dioxide Box . . . . .	16

### Wings

<b>Investigating the Physics of Flight</b> . . . . .	19
Hot Air Balloon . . . . .	20
Hero's Engine . . . . .	22
Sonic Cannon . . . . .	24
Balloon Jet . . . . .	26
Effervescent Rocket . . . . .	30
Straw Rockets . . . . .	33
Straw Rocket Gliders . . . . .	34
Answers to Questions and Thinkers . . . . .	36

# Foreword

Welcome to Wind, Water, and Wings: Aviation Activities for the Classroom. The activities in the book are designed to give students hands-on experience with weather and flight related phenomena.

The activities in the first half of the book are designed to help students understand the air around them and how it impacts their daily activities, as well as flight. The activities included in the second half of Wind, Water, and Wings bring the students in contact with aircraft that span the aviation time line.

The activities were chosen for their ability to engage students' imagination, their educative qualities, and their relative low cost. They are but an introduction to the possibilities available with aviation related activities.

# Wind and Water

## Investigating the Weather

### Weather

Weather is a daily factor that generally affects our lives. The weather often controls our activities or causes us to change our plans. While obtaining the weather forecast from the media has become a common part of our routine, the weather has always played an integral part in aeronautical operations. The wind influences the course flown by the pilot. Temperature, humidity, and barometric pressure affect the performance of the engine and lifting surfaces of the aircraft. Storms and other forms of inclement weather may prove detrimental to the safety of the flight.

Aviators not only concern themselves with weather conditions on the surface of the earth, they also take into consideration the weather aloft. Wind direction and speed change as the aircraft gains altitude. The temperature and barometric pressure drop as the aircraft ascends. Pilots must consider the moisture in the air when navigating. If a plane flies through clouds at high altitudes, ice may form on the exterior surface of the aircraft. Ice will change the shape of the surface, reducing the amount of lift generated by the wings, and force the aircraft to descend. Visibility may be limited by smoke, haze, pollution, and other factors. In general, accurate information concerning the weather is paramount to aviation safety.

Several topics of discussion addressing meteorological issues are presented in this section. In particular, barometric pressure, temperature, humidity, and wind are highlighted. To enhance knowledge concerning various aspects of weather, instructions for the construction and utilization of a select group of simple weather instruments are included.

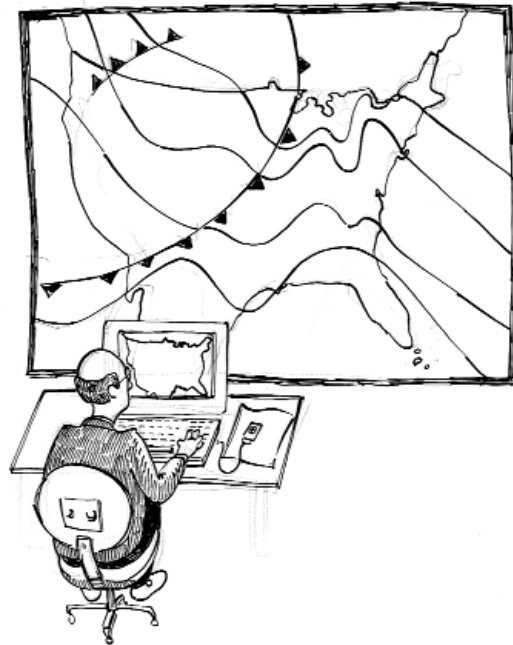

### Barometer

Instruments used to measure the weight of the atmosphere are called barometers. They range from simple devices to elaborate instruments. Meteorologists use barometers to report the "barometric pressure." Changes in the barometric pressure reveal shifts in the weather. Typically, low pressure fronts are associated with inclement weather and high pressure fronts correspond with fair weather patterns.

Several classroom exercises concerning barometers may be conducted using common household items. In addition, students should be encouraged to listen to the barometric pressure given during the weather report and note associated weather patterns.

# Dewpoint

When the dewpoint and the temperature are close or equal, clouds or fog may form. We need a method of measurement to predict when this will happen. Dewpoint is the temperature at which water vapor condenses. This means it will become visible. Clouds and fog are formations of condensed water vapor.

In this experiment, we will learn just how the dewpoint is set. The following equipment and materials are required.

1. A smooth sided, shiny tin can
2. A glass laboratory thermometer
3. Ice cubes
4. Water at room temperature

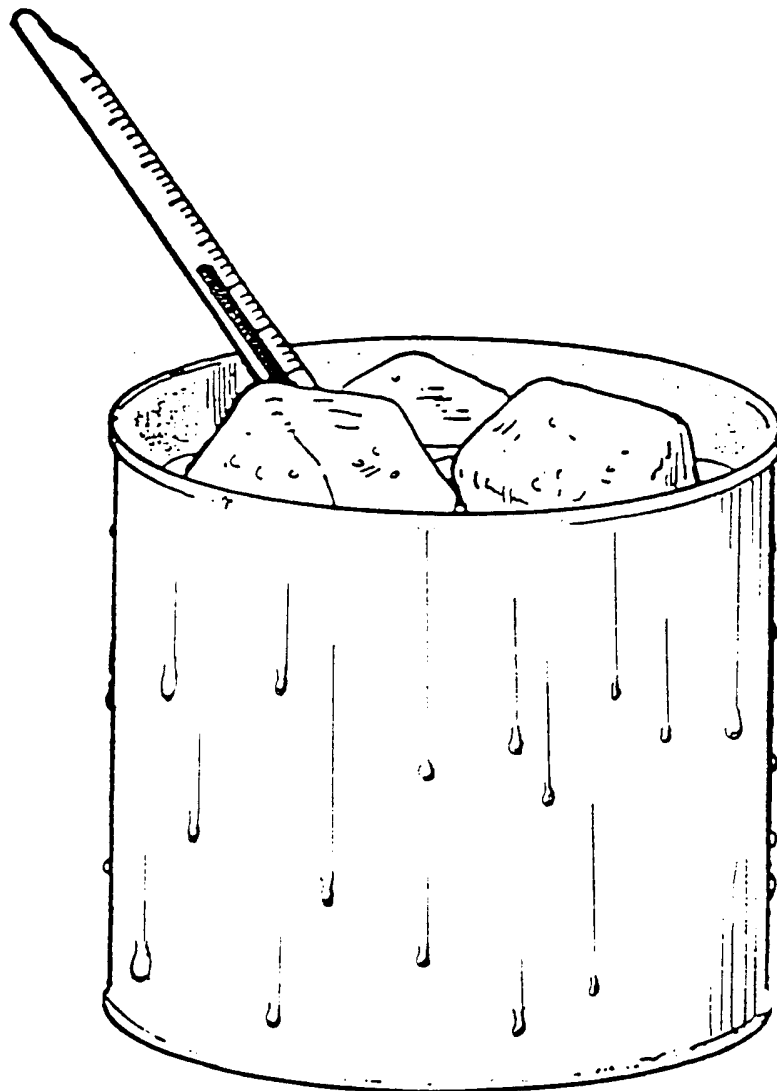

Fill can about three-fourths full with water. Test the water temperature with the thermometer to be sure it is at room temperature. Add three ice cubes to the water. Do this carefully so the water temperature will lower slowly. Observe the outside of the can. As soon as moisture starts to form, read the temperature again. This reading will be the experimental area's dewpoint.

1. Why is it important to know the dewpoint?
2. Can meteorologists determine the icing altitude by knowing the dewpoint?
3. Why should we use a shiny tin can for this experiment?

**THINKER 1** - If the dewpoint is 48° F (9° C) and the temperature is 64° F (18° C), what is the local cloud base altitude?  
(HINT: Temperature decreases 4.5° F per 1,000 feet.)

*Answers on page 36*

# Frontal Movement

We will see just how a warm front runs over a cold front in this demonstration. We need these materials.

1. Rectangular Pyrex container, three by four by 10 inches (7.6 x 10 x 25.4cm)
2. Sheet of heavy acetate (overhead transparency stock)
3. Food coloring (red and blue)
4. Modeling clay (oil base)
5. Table salt
6. Flat clear glass bottle, pint or quart size (optional)
7. Heavy motor oil (optional)

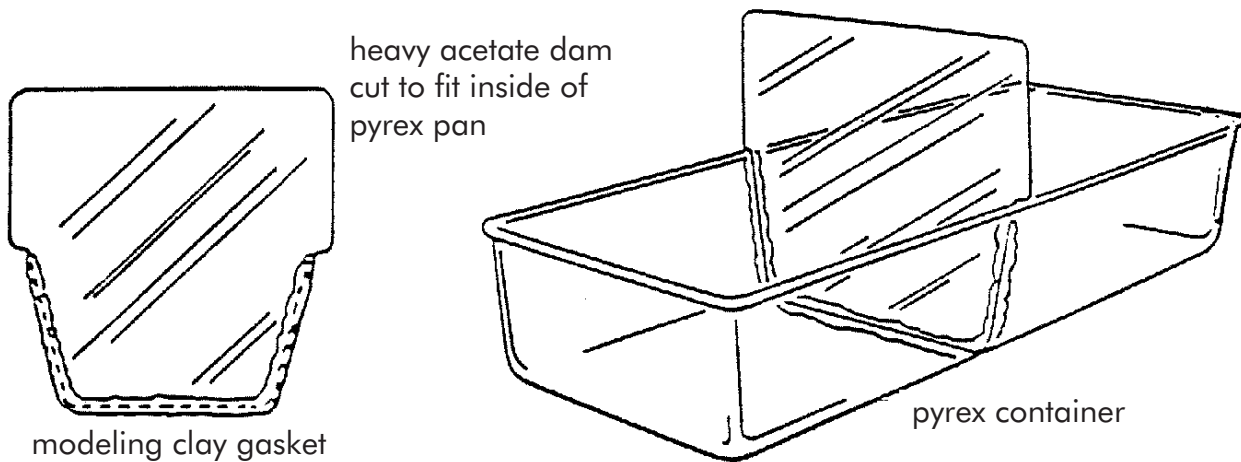

OR

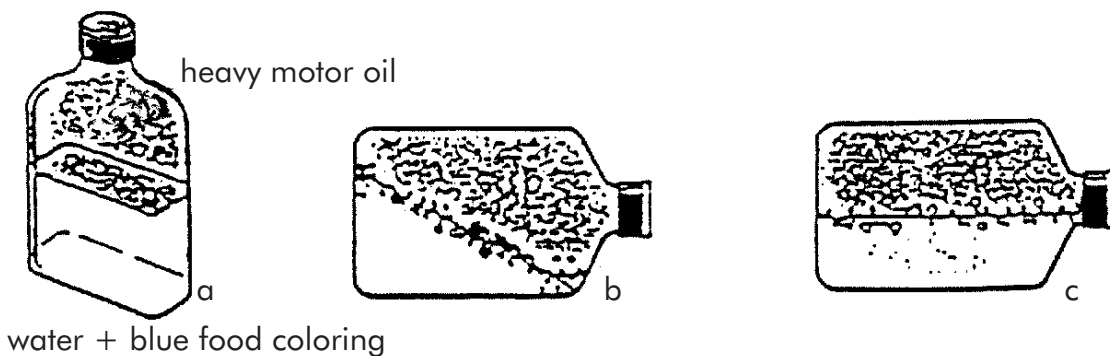

Cut a dam from the acetate. It should fit the inside of the Pyrex container. Now make a coil of modeling clay and press it around the dam. Place the dam in the center of the container. Shape the clay gasket to fit. Press the clay firmly to the dam to seal it. Check to see if the clay gasket and dam can be removed from the container in one movement.

Now, fill the Pyrex container with water. Place the dam in the center. Add  $1\frac{1}{4}$  tsp. of salt to the water on one side of the dam plus five or six drops of blue food coloring and mix. Add five or six drops of red food coloring to the clear water and mix.

After the water has settled, carefully lift the dam and observe the result. You should be looking at the side of the container.

The following experiments are optional.

1. Replace the dam in the previous experiment and mix the solution on one side of the container. After the mixture has settled, remove the dam and observe the results.
2. Pour heavy motor oil into the bottle until it is half full. Fill the remainder of the bottle with water that has been colored with blue food coloring. The water will settle to the bottom. Turn the bottle and observe the results.

**1.** What do the two different colors of water represent?

**2.** Why does the blue water act the way it does?

**3.** Why does the violet layer act the way it does?

**THINKER 1** - What does the action in the tank with the red and blue water tell you about frontal activity?

*Answers on page 36*

# Differential Pressure

Aircraft are machines that use various laws of physics to achieve flight. In general, the major force employed for mechanical flight is differential pressure. To establish a different pressure, at least 2 pressures of different magnitudes are placed in opposition to each other across the surface area of an object. In such scenarios, the item experiencing the differential pressure attempts to move away from the source of high pressure toward the area of low pressure. From this basic reaction desired outcomes are generated (e.g. airfoils develop lift, propellers generate thrust, fuel flows to its discharge nozzle, etc.).

In aeronautics, the establishment of the proper amount of differential pressure is paramount to the operation of aircraft. Furthermore, the pressure differential must be distributed across an appropriate amount of surface area. Such requirements are evident as one evaluates the basic form of an airplane. The shape of the wing produces

## Bernoulli's Principle

Daniel Bernoulli (1700-1782) was a Swiss scientist that studied fluid flows. From this work emerged "Bernoulli's Principle." This law states that for a steady flow of fluid, the total energy (combination of kinetic energy from the velocity of the flow, the potential energy from elevation and gravity, and the pressure energy exerted by the fluid) remains constant along its flow route. Therefore, when velocity increases, the pressure energy of the fluid must decrease to maintain a constant level of total energy.

the essential pressure differential when the aircraft is at or above its minimum speed necessary for flight. The size of the wing provides the requisite surface area needed to generate lift from the pressure differential generated by the airfoil. Therefore, lift is generated by establishing and distributing a pressure differential across a surface.

In this unit, several examples for demonstrating the principle of differential pressure are presented. Many illustrations are based on "Bernoulli's Principle." Where Bernoulli's Principle involves the dynamic action of air in motion, a number of experiments demonstrating differential pressure in this section are presented using static conditions.

In simpler terms, as velocity increases, pressure decreases.

Bernoulli's Principle is used throughout the entire aviation industry. From the production of lift to the workings of a carburetor, the relationship between velocity and changes in pressure is critical. As might be expected, Bernoulli's Principle is also prevalent in other industries.

# Funnel Demonstration

As previously presented, Bernoulli's Principle states that as the velocity of air increases, its pressure decreases. Bernoulli's Principle may be demonstrated by placing a ping pong ball in the funnel while it is upright. Blow through the funnel as though you were going to launch the ping pong ball from the funnel. Most people are surprised when the ball remains in the funnel. In fact, blowing as hard as you can only serves to keep the ball more firmly in the funnel. If you are blessed with an uncanny ability to exert a lot of wind, you can begin blowing and invert

the funnel while you blow. Surprisingly, the ball remains in the funnel until you run out of breath.

What makes this demonstration work is the differential pressure that forms when you have low pressure acting in the funnel and atmospheric pressure (which is higher) outside the funnel.

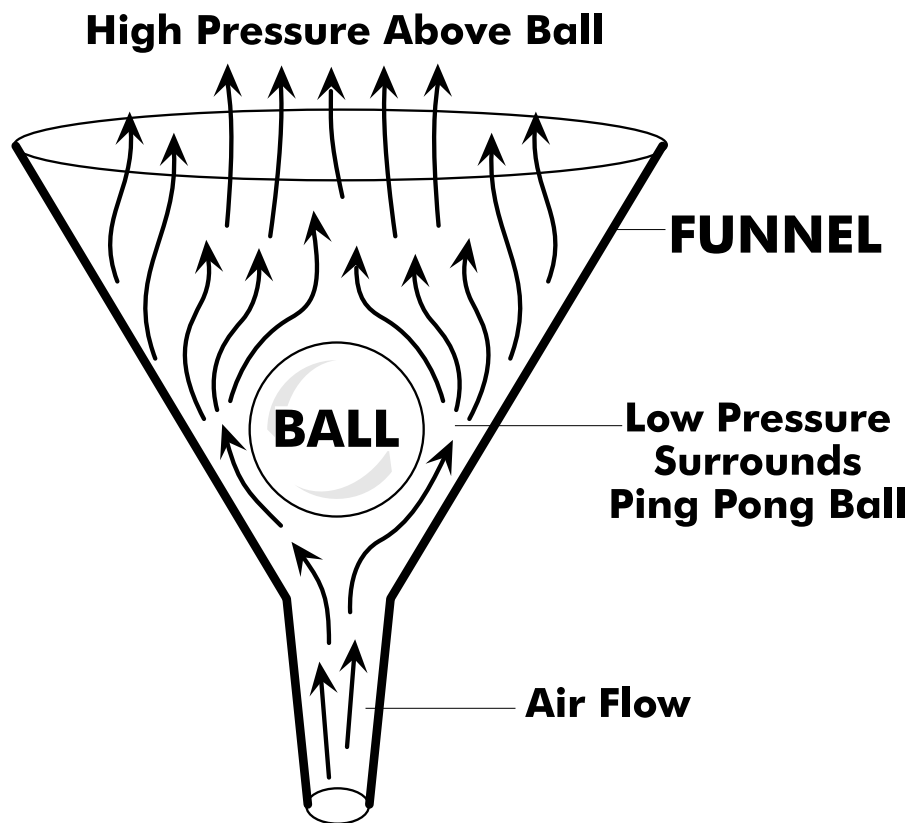

# Flying Beach Ball(s)

A common department store display may be used to demonstrate Bernoulli's Principle. Given a fairly powerful fan and inflated beach ball, direct the blast from the fan so that it is upward. Next, place the inflated beach ball in the moving airstream. Note how the ball remains suspended in the airstream. Gently grab the beach ball with both hands, and slowly pull it towards you. As the ball is pulled from the airstream, you will feel a force trying to pull it back into the airflow. This reaction is due to the pressure differential generated between the surface of the beach ball exposed to the accelerated airflow

and the relatively stationary air outside the perimeter of the fan's blasts. As revealed by Bernoulli, the moving air mass on one side of the ball has less pressure than the stationary air on the other side of the ball. This action produces a pressure differential across the ball. You can feel this force by the tendency of the beach ball to oppose being removed from the center of the fan blast where it is surrounded by an area of low pressure. Release the partially extracted beach ball and note how it darts back into the flowing airstream.

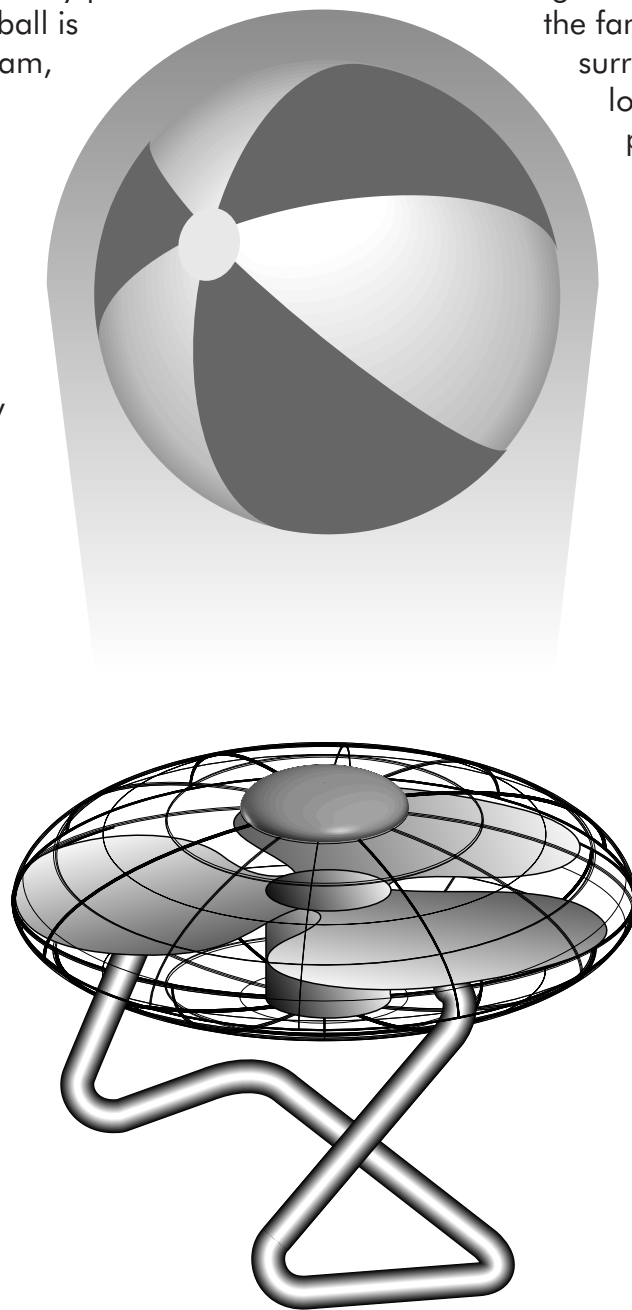

Try tilting the angle of the air blast from vertical to some other angle. If the flow generated by your fan is strong enough, the ball will float in midair. The reason this works is because of the low pressure that surrounds the ball. As gravity tries to pull the ball to the ground, a pressure differential exerted across the surface of the ball keeps it in midair. The low pressure above the ball plays a major role in suspending the ball in the atmosphere. Move the fan around and note that the ball follows the airflow.

If you have a powerful fan, place two beach balls in the airstream. Note how they battle for the center of the airstream. As they bounce off each other, observe how they move towards the center of the air blast only to bounce off each other in a repeated fashion. Remember from the previous demonstration using a single beach ball, when you gently and slowly pulled the ball from the airstream, a portion of the beach ball exited the airstream and produced a pressure differential that pulled the ball back to the center of the following air mass. In this demonstration, the two beach balls are trying to occupy the same location as they seek the area of low pressure.

Similar demonstrations may be performed using a powerful blow dryer and ping pong

ball. Substituting a blow dryer for a house fan is both economical and less bulky. However, it is difficult to sustain two ping pong balls in the air using a hair dryer.

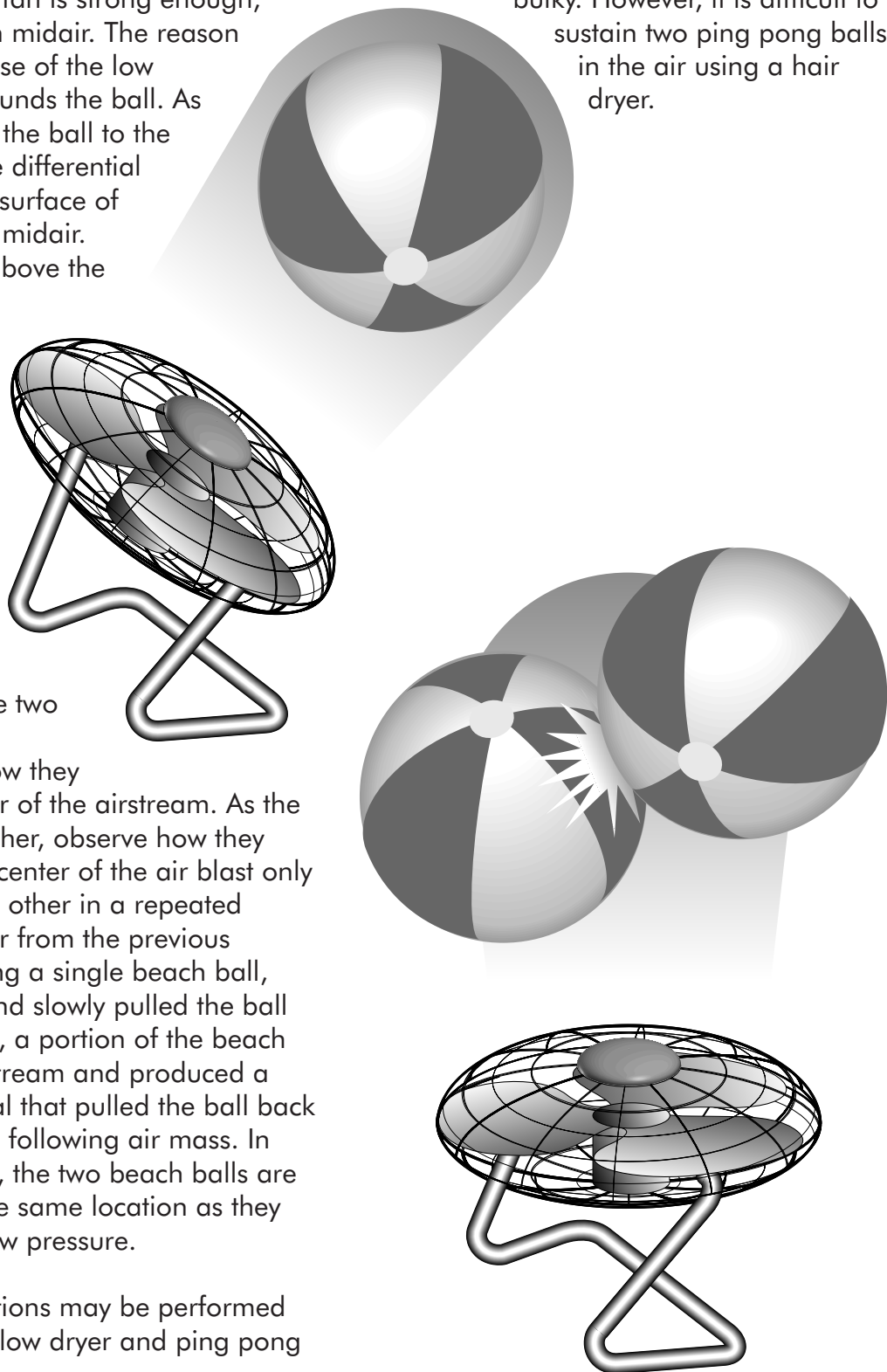

# Air Pressure Demo

## Objectives

The student will observe the principles of air pressure.

## Grade Level 5-8

Time needed: 30 minutes

## Materials

Hose from a vacuum cleaner or other flexible, wide tubing; ice cream bucket; confetti; and bird seed or tissue paper.

## Procedures

1. Place the confetti, bird seed, etc. in the bucket or place a piece of tissue paper on a flat surface.
2. Hold one end of the hose just above the substance in the bucket or the tissue paper.
3. Have students hypothesize what will happen when the loose end is swung in a circle.
4. Start to swing the hose in a circle above your head.
5. Have students record observations.

## Principles Observed

As the hose is swung in a circle, it creates an area of low pressure at the end of the hose above your head. This low pressure area caused the confetti to be pulled up and out of the hose. This is an example of Bernoulli's Principle which states that pressure is lower in a moving fluid.

Have students answer the question: How does a vacuum cleaner work? What creates the suction?

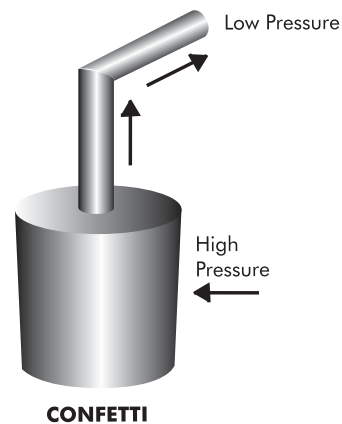
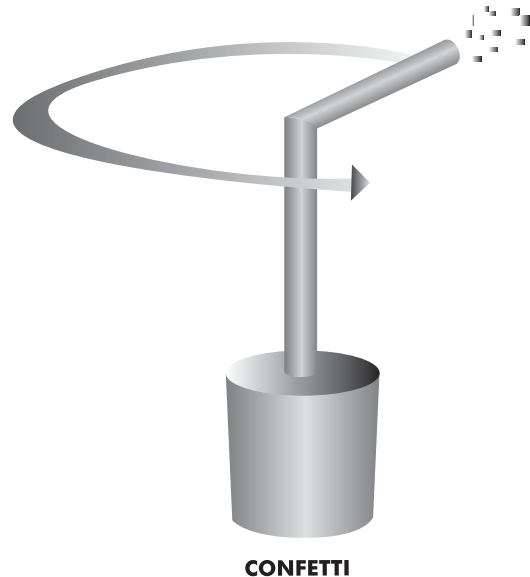

# Air Displaces Water

Almost reminiscent of the evil scientist pouring liquids from one beaker to another, this demonstration not only shows that air occupies space, but that it displaces water from an inverted cup. To conduct this experiment, partially fill an aquarium with water. Make certain to have enough water to allow you the ability to maneuver your cups without spilling water over the top of the aquarium. Using two cups, they should be transparent and for safety reasons made of plastic, invert one cup in the aquarium keeping it filled with air. The other cup should be initially submerged in an upright position to fill it with water. The water-filled cup should then be inverted and positioned so that it is above the inverted cup filled with air. Slowly tip the air-filled glass so that the rising air enters the inverted water-filled cup. As the air transfers into the water cup, the liquid is displaced. By the end of the process, the cup that had the air is now filled with water and the original water cup is filled with air. It takes a little practice to keep from letting the air escape from the containers.

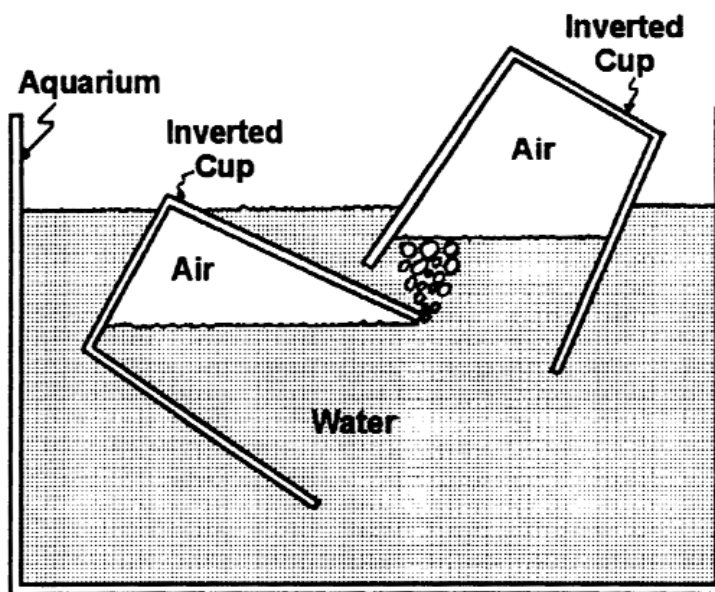

**Pour Me a Cup of Air**

# Air Occupies Space and Has Body

Demonstrating that air occupies space can be readily shown by inflating a balloon or a tire, those techniques may be less obvious than simply inverting a glass over an aquarium filled with water and shoving the cup (please use plastic) to the bottom. To stir some creative thinking, ask the participants how they can send the cork to the bottom of the aquarium without touching it. The solution is simple. Capture the cork with an air-filled, inverted cup and force the cup to the bottom of the aquarium. The cork will then be resting on the bottom without being touched directly by your action.

You may note a small amount of water trapped within the confines of the inverted cup. A partial reason for this is due to the air compressing inside the inverted cup as it is placed deeper and deeper in the aquarium. If the aquarium was sufficiently deep, you would notice that water begins to fill the glass as it descends. This is due to the equilibrium being established between the water and the air and the compressibility of the air.

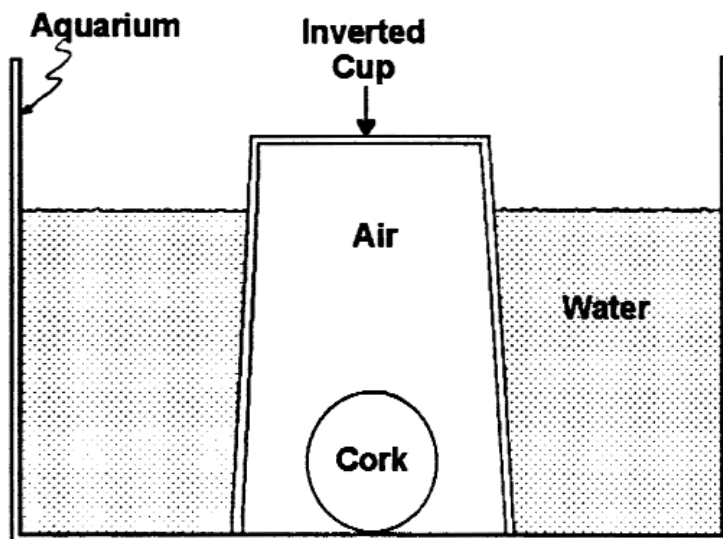

**Forcing the Cork to the Bottom**

# Using the Atmosphere to Lift Water

With a partially filled aquarium, cup, and buoyant object, a demonstration showing how the weight of the atmosphere can lift a column of water may be shown. Make certain that the water level is near the top of the aquarium. In this experiment, challenge your students or participants to devise some means of raising the buoyant object floating on the water so that it is above the aquarium itself. They are not allowed to scoop the floating object with their hands or other device.

The solution is to use atmospheric pressure. First capture the floating object with an inverted transparent cup (use plastic for safety reasons). Next, carefully tip the cup so that the air escapes and all that is left in the inverted cup are water and the buoyant article. Lift the inverted cup and witness that the water and floating object remain in the cup even after its height exceeds the uppermost surface of the aquarium. Don't lift the rim of the inverted glass above the level of the water.

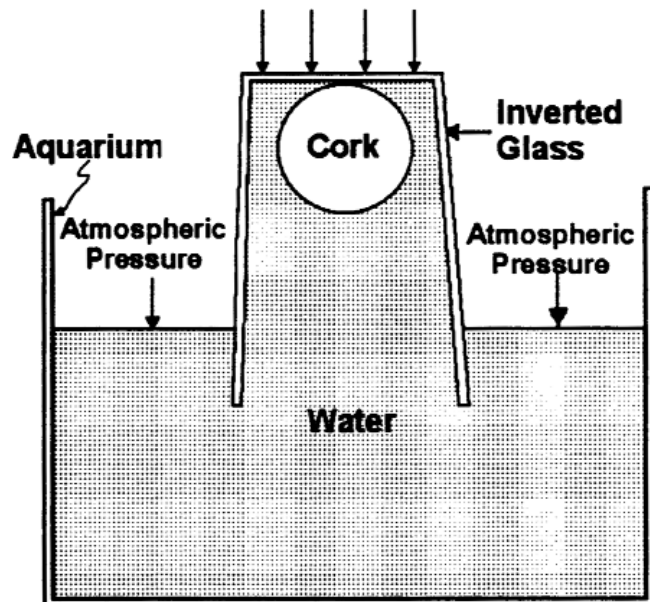

**Using Atmospheric Pressure to Lift Water**

# Carbon Dioxide Demo Box

Carbon dioxide is all around us in the air that we breathe. Less than 1% of our atmosphere is made up by this compound. Carbon dioxide is tasteless, odorless, invisible, does not support combustion and forms dry-ice when compressed.

To show some of these properties we will construct a demo box out of these nine materials.

1. A sturdy cardboard box (12" x 12" x 18")
2. Six sheets of overhead transparency film
3. Tape, transparent or masking
4. Sharp knife or razor blade
5. Small shallow metal pan
6. Dry-ice
7. Water
8. Clear plastic drinking glass
9. Small candle

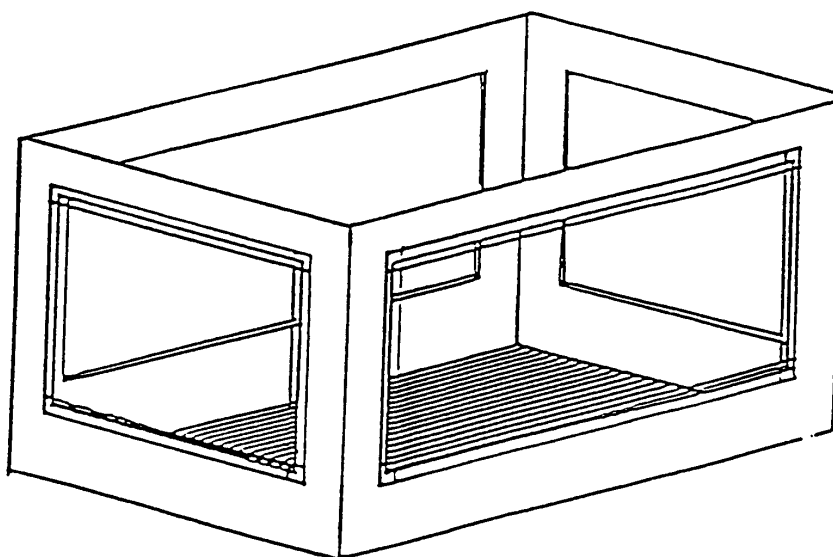

Start the construction of the box by removing the top flaps with your knife or razor blade. Turn the box over and tape all the seams to make the bottom as airtight as possible. Next draw rectangles on all four sides of the box about 1" smaller than the transparent sheets to be used. Place the sheets over the opening and seal in the place with the tape, making four airtight windows in the box. We are now ready to start the demo.

Start by placing the small pan in the bottom of the box in which a small amount of water has been added. Next add the dry-ice, which has been broken into small chunks. At this point let the box and its contents rest for a short time while the  $\text{CO}_2$  is being generated.

We now have a box full of carbon dioxide and are ready to discover some of its properties. First, lower a lighted candle into the box. When the candle goes out we have established the level of gas. Next, dip the plastic drinking glass into the box and carefully pour the gas over a burning candle. What happened? Again, fill the glass with carbon dioxide gas and add water. Does it taste like carbonated water?

**1.** What is the temperature of the dry-ice?

**2.** What can you tell about the weight of carbon dioxide as it relates to the air around us?

**3.** List as many uses as you can for this gas

**THINKER 1-** How do you suppose carbon dioxide works in putting out a fire?

*Answers on page 36*

## **CAUTION**

---

Dry-ice is extremely cold. **DO NOT TOUCH WITH BARE HANDS!** Use only a set of tongs or heavy gloves when handling the dry-ice. Use a hammer or ice pick to break off the chunks.

**PLEASE BE CAREFUL!!!**

---

# Wings

## Investigating the Physics of Flight

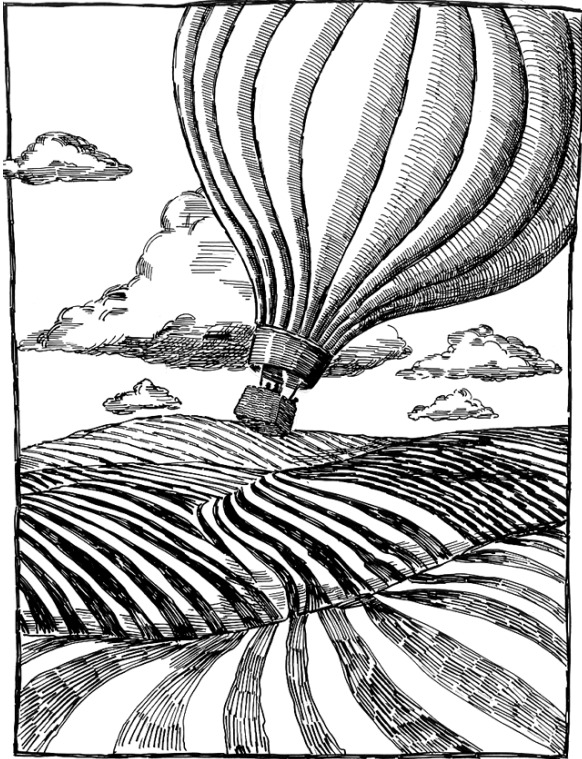

### Important Dates in Aviation History

**1783-** The first recorded ascension of a hot-air balloon, built by Joseph and Entienne Montgolfier, was on June 4, in France. Three months later, the Montgolfiers launched a hot-air balloon for King Louis of France, carrying a duck, a rooster, and a sheep. On November 21, Pilatre de Rozier and the Marquis d'Arlandes made the first manned balloon flight, lasting 25 minutes and traveling a little over 5 miles. On June 4, 1784, Marie Thible of France became the first female aeronaut.

**1849-** In England, Sir George Cayley built the first successful manned glider. He formulated the basic principles of heavier-than-air flight and turned aviation from a fantasy into a science. Because of his contributions Sir George Cayley is called the "father of aerial navigation."

**1903-** On the wind swept sand dunes of Kitty Hawk, North Carolina, Orville Wright successfully flew the first recorded powered, heavier-than-air flight in the United States. It lasted 12 seconds and traveled 120 feet.

**1927-** Charles Lindbergh became the first person to fly solo across the Atlantic Ocean. His flight of about 3,600 miles from New York to Paris lasted  $33\frac{11}{42}$  hours (49 years later, the Concorde, traveling at Mach 2, made the same flight in 3 hours).



**1944-** The first production jet-powered aircraft, the ME 262, was introduced into combat by the Germans.

**1952-** The Comet, built by the de Havilland Aircraft Company, became the first commercial jet airplane.

**1954-** Two Comets, one in January and one in April, exploded in flight on clear days. All were grounded, and for the next year extensive research was conducted to solve the mystery. The conclusion: they were not built to stand the pressure changes that occur when the plane rapidly climbs and descends to its normal flight level.

**1958-** The Boeing Company watched and learned from the Comet experience and rolled out their first commercial jet, the 707, ushering in the jet age for commercial travel.

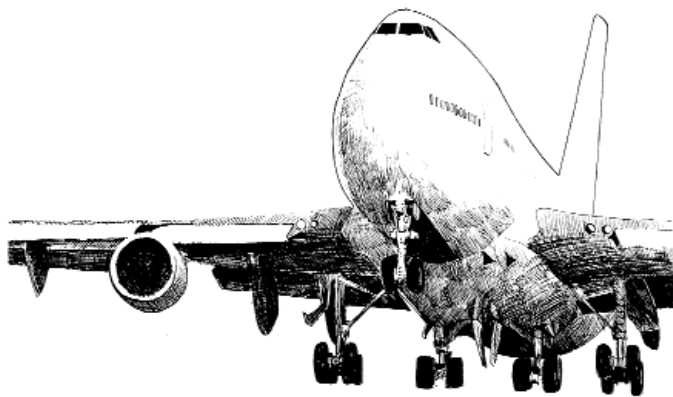

**1957-** The Soviet Union launched Sputnik, the first artificial satellite to orbit the earth.

**1961-** Russian Yuri Gagarin became the first person to orbit the earth in space.

**1969-** American Neil Armstrong became the first person to walk on the moon.

**Today-** The space shuttle orbits 250 miles above the earth, traveling at 17,500 mph, and it takes just 90 minutes to complete a trip around the world.

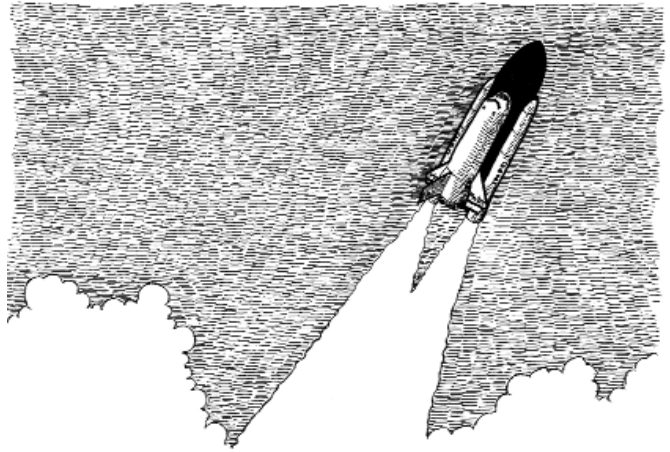

# Hot Air Balloon

A good introduction to this project is talking about the hot air balloons students have seen and how they work. There are also a lot of good books on the subject. For fifth and sixth graders, *Hot Air Henry*, by Mary Calhoun, is a good one to read first.

## Materials (for one 5ft. Balloon)

1. Six panels of jewelers' tissue, dimensions below (Jewelers' tissue is 20" wide, so you don't have to piece it together. If unavailable, glueing regular tissue paper together will work).
2. Markers.
3. Elmer's glue or 4-5 gluesticks.
4. Hot air popcorn popper or hair dryer may be used for the five foot balloon. The nine foot pattern requires a commercial hot air balloon launcher. They are available from companies such as PITSCO, use propane, are safe, and cost around \$80.
5. A place to launch - a gym is best. The cooler the room, the better. Outdoors, a calm day and an open field away from power lines and traffic are needed. A commercial launcher removes the difficult-ies involved when using an extension cord for the hair dryer/popcorn popper.
6. Rubber bands.
7. String.

## Procedure

1. Create a tagboard template for students to use to trace the shape of the panels onto the tissue (pattern information is on the next page). Students can trace and cut their own panels, or panels can be cut and ready to decorate for younger students.
2. Students can work in small groups to design and color their panels. It is helpful to avoid letters and numbers because when the panels are put together, some may be backwards. They only have to color one side because the markers bleed through. Put newsprint under the panels before coloring.
3. The six panels go together like an accordion. First lay one down and put a continuous thin line of glue along the entire left side. Younger children could use glue sticks. It's very important that the glue line does not stop and start, which makes a hole for air to escape.
4. Put another panel right on top. Now you have the left side glued together. Put a thick glue line along the right side of this panel.
5. Lay another panel on top. Put the thin glue line on the left side. Continue laying panels on top and putting glue on alternate sides till the six panels are all on the pile. Glue the two open sides together.
6. To seal the top, tie the string or thread about two inches down. Leave the bottom open.
7. To launch, hold bottom down over hot air popper/hair dryer or launcher and let the balloon inflate. It'll feel hot and start tugging. At that point, take the bottom, squish it together, wrap the rubber band around it, and let it go quickly. An adult should do most of the holding because these appliances become very hot (with the exception of the commercial launcher)

and could cause burns. If you're inside, the balloon will rise and stay up until the air inside it has a temperature (and weight) equal to the room air. If the room is cool, it will stay up longer. The students can time how long it's up. They can talk about variables, comparing results if the balloon is launched at different times of the day when the room is warmer or cooler, or if the length of time the balloon is heated makes a difference.

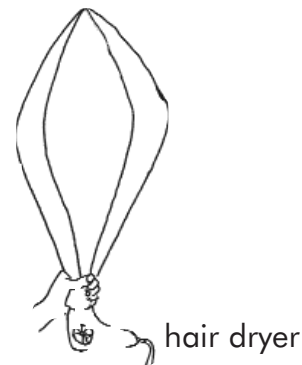

Five foot balloon pattern

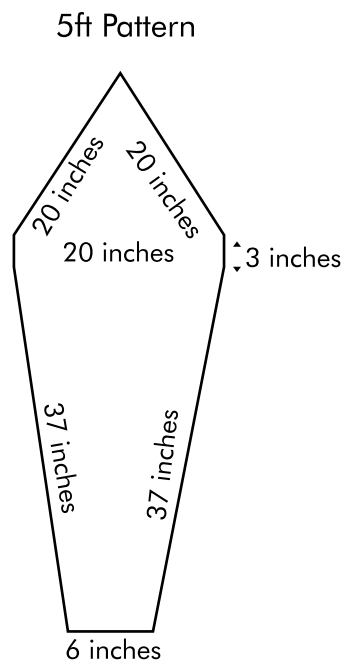

For a nine foot balloon, use ten 9 foot panels.  
(Requires commercial launcher)

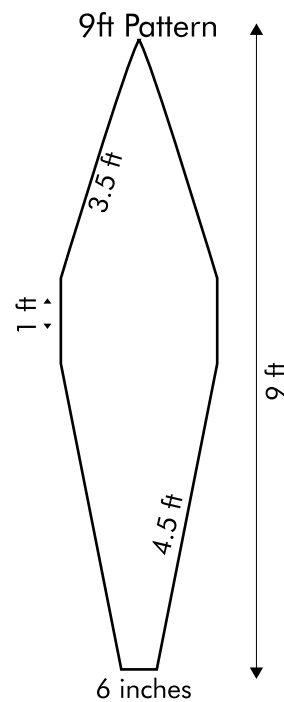

# Hero's Engine

## Historical Background

Hero of Alexandria conducted many experiments related to hot air, steam and mechanics. All of his work was done before 300 AD, which is quite remarkable viewing the technical nature of his inventions. The Aeolipile, pictured here, is a kind of steam turbine. The tubes fixed to a hollow sphere had ends bent over in opposite directions. The sphere was mounted over a boiler; steam passed into it through the hollow bearings; resulting in the steam escaping through the tubes, under pressure, causing the sphere to rotate.

## Classroom Application

A model of Hero's engine can be used quite successfully in the classroom to demonstrate a number of different principles. The three that can be best related to aerospace would be; Newton's third Law of Motion; the power of steam under pressure; and the principle of a rocket or jet engine. All of these demonstrations relate to the action/reaction principle and can be used to assist the students memory of these truths.

## Necessary Construction Materials

1. One Copper tank float
2. Short eye bolt ( $1\frac{1}{4}$ " x 20,  $\frac{31}{44}$ " long)
3. Two  $\frac{11}{48}$ " copper tubing, 2" long
4. One medium fishing swivel
5. A short piece of cord
6. Tools: soldering equipment and an awl

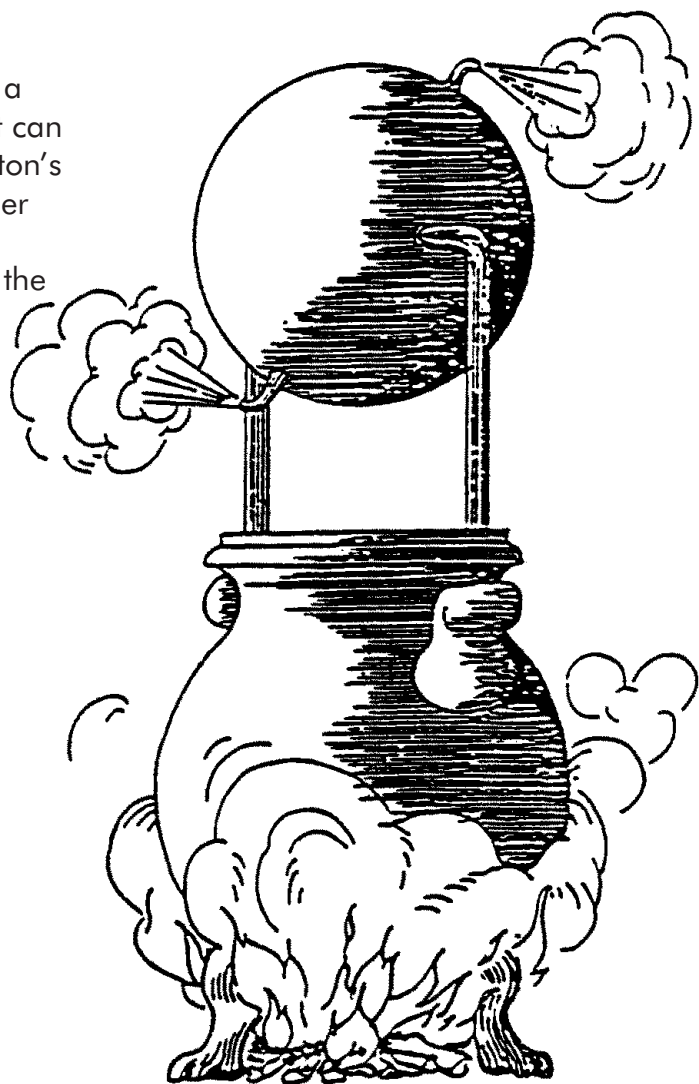

## CAUTION

Exercise extreme care in using the torch and avoid eye contact with the resulting steam, both of these elements are very hot and can cause serious burns!

**PLEASE BE CAREFUL!!!**

### Construction

Start by bending soft 90 degree bends in both  $\frac{1}{48}$ " copper tubes. Next, using the awl, punch two holes about  $\frac{1}{48}$ " above the center seam of the float and 180 degrees away from each other. Make these holes so that the copper tubes fit very tight and position them as shown in the diagram. With the tubes in place solder them carefully so that no steam can escape around them. Screw in the eye bolt, connect the fishing swivel and tie on the cord. Your Hero Engine is ready to use.

### Demonstration Procedure

Set the engine in a stand, as illustrated below. Fill the engine with about 10 to 12 cc's of water through one of the copper jets using a large syringe. Place a heat source under the float until steam starts to escape from the jets. (Probably the best heat source is a propane torch as the RPM's can be charged by moving the torch to or away from the float.)

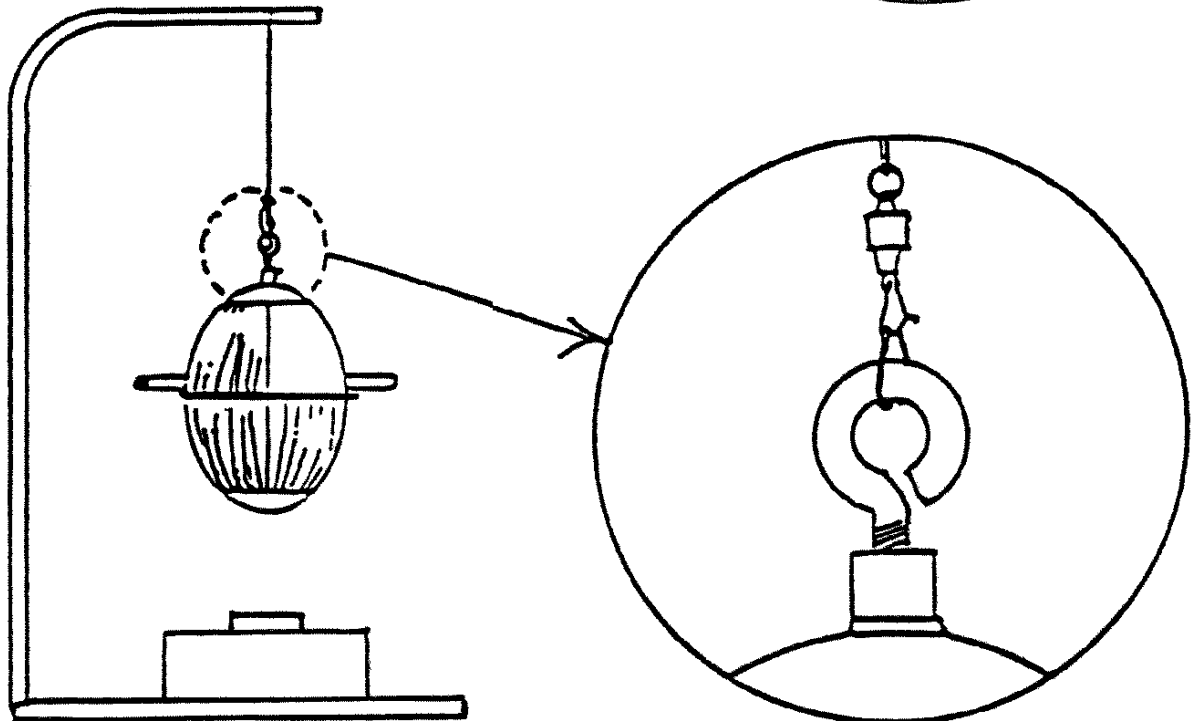
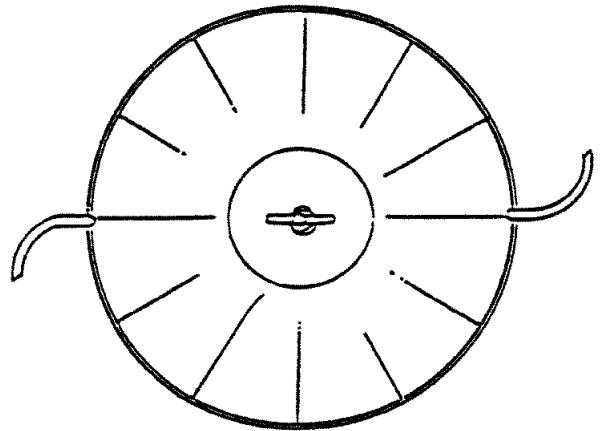

# Sonic Cannon

We can hear sounds and sometimes feel their power. In this experiment, we will work with the power of sound waves. To show their strength, we will construct a cannon that "shoots" sound. We have two alternatives for construction.

## (A)

1. A cardboard mailing tube  $2\frac{1}{42}$ " (6.4cm) in diameter and about 18" (45.7cm) long
2. Two index cards
3. White glue
4. One candle

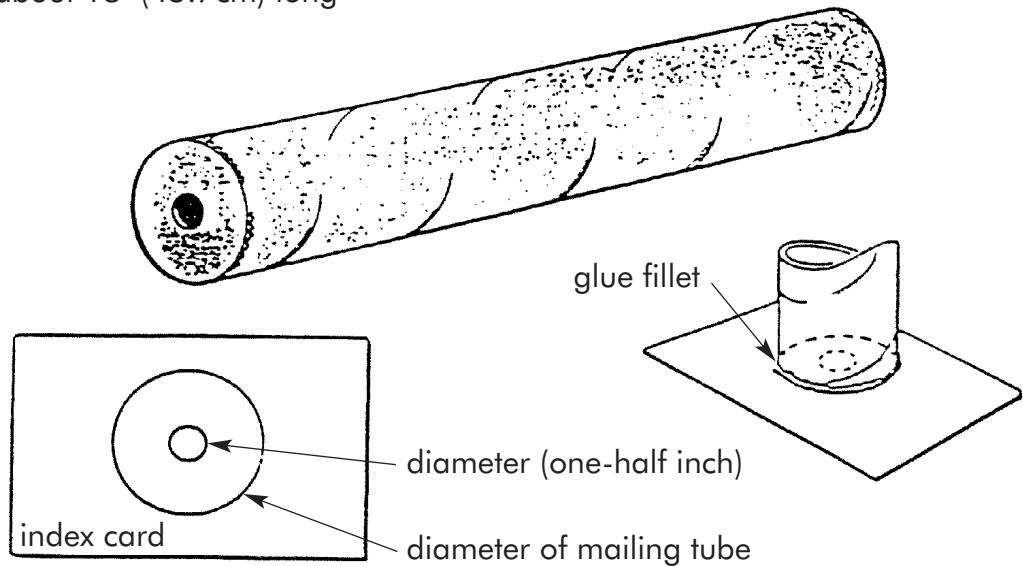

## or (B)

1. Two Pringles Potato chip canisters
2. Two rubber bands
3. Two large paper clips
4. A  $\frac{3}{48}$ " nut
5. Tape
6. One candle

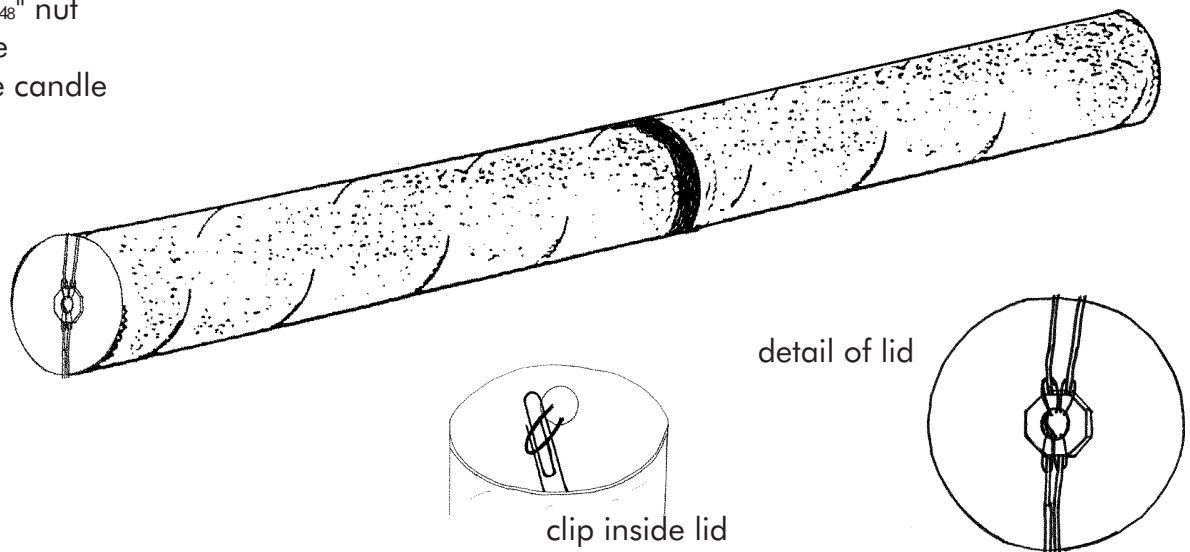

**A.** Draw a circle with the same diameter as the mailing tube on each of two index cards. On one card, cut a concentric circle  $1\frac{1}{42}$ " (1.25 cm) in diameter inside the larger one. Place a heavy coat of glue on both ends of the tube and press the circles against the glue. When it dries, trim off the excess index cards. (Be sure the cards are glued securely to the mailing tube.)

**B.** Remove bottom metal rim of the first canister. On this canister punch two holes just below top rim, opposite each other. Tie ends of rubber bands to  $\frac{3}{16}$ " nut. Attach paperclips inside the tube to other ends of rubber bands. Replace plastic lid under rubber bands, making sure nut is outside. On the second canister punch  $1\frac{1}{42}$ " hole in the center of bottom. Remove top metal rim. Place canisters, open ends together. Seal with tape to complete.

We now have a sonic cannon. We will use a burning candle to demonstrate the cannon's power. Place the flame about 12" (30.5cm) away from the hole of the cannon. Snap the solid end of the cannon with your finger or draw back nut and release, (with a little practice, you will be able to put out the flame with a snap.) Change the distance between the candle and the cannon and repeat the experiment. How far can you get away from the candle and still put it out?

**1.** Do the air molecules and the sound waves move at the same speed?

**2.** Why is the small hole necessary?

**THINKER 1** - What do you suppose the shape of the invisible sound wave is?

*Answers on page 36*

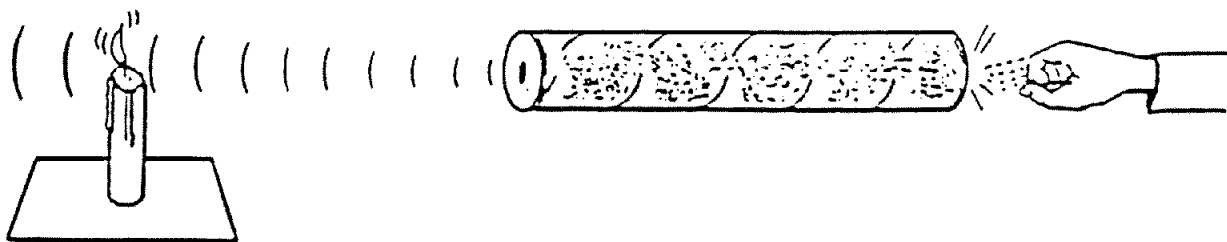

# Balloon Jet

The Balloon Jet project was inspired by an idea in *The Berenstain Bears FLY-IT! Up, Up, and Away* book by Stan & Jan Berenstain.

## Objective

The students will be able to demonstrate and describe how a jet engine works while working with the concept of thrust and compression. Have students note that a jet engine is divided into three main parts:

- A: The Compressors.
- B: The Combustion Chambers.
- C: The Turbines.

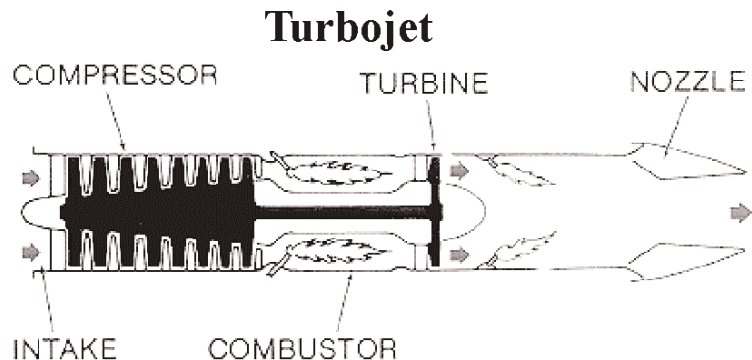

## Principles Observed

Sir Isaac Newton's Third Law of Motion states that for every action there is an equal and opposite reaction. A jet engine uses this principle by taking in air, a gas, on one side, energizing it by compression and rapid expansion, and using that energy to create a reaction, namely thrust out the opposite side. The balloon is simulating the idea of compression and thrust, or rapid expansion. This experiment also shows the efficiency a jet engine has by channeling all reactive energy in one pointed direction.

## Materials needed

1. Long party balloons (the type that can be used to make balloon animals).
2. A balloon pump (approximate \$4.00).
3. Fishing line (thin, thread-like line works better than thicker, blue translucent line).
4. Tape.
5. Small straw or swissel stick.
6. Balloon jet pattern (see pages 28 & 29).

This experiment will deal mainly with the thrust created by compressing a gas and letting it expand out of a smaller area.

## Procedure

1. Color and cut out the stabilizers, wings, nose cone, and jet body.
2. Bend and tape the jet body into a tube shape. Having a 1<sup>11/42</sup>" plastic pipe to wrap the body around will make this task easier.
3. After bending on the dotted lines, tape the stabilizers and wings to the jet body.
4. Curl and tape the nose cone so it is the same size as the jet body. If it is larger than the jet body, it will rub against the fishing line and reduce performance.
5. Run fishing line through a small stirring straw (swissel stick) and attach each end of the line to a chair.
6. Attach the jet body to the straw with cellophane tape, make sure the fishing line runs between the stabilizers and will not get caught on the nose cone.

7. Inflate and insert a balloon into the jet body, pinching the opening of the balloon closed with your fingers. The jet will work most effectively if the balloon is not bent to one side. Balloons are flexible enough to be gently straightened.
8. Release the balloon.

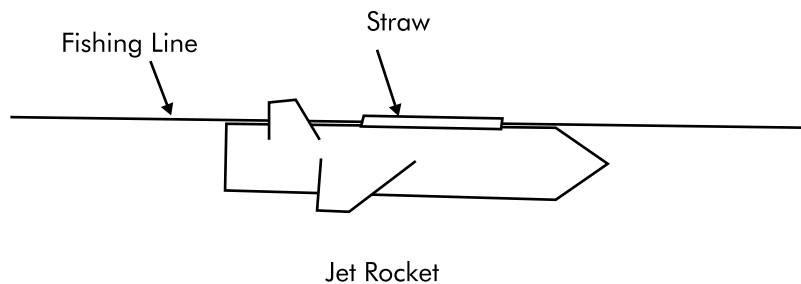

### Extension Ideas

1. Have the students experiment with different sizes or types of balloons, jets and straws. Make a chart recording the effects of the different variables.
2. Move the string from a horizontal to a vertical position. Which jet goes the highest? What forces are working against the jet?
3. Use the energy from the balloon to power free-flying aircraft which the students could design and build.
4. Discuss the concepts of energy, potential energy, and equilibrium in balloons.
5. Allow students to attach a small piece of straw to the mouth of the balloon to create a smaller hole (See diagram). The smaller hole will result in a greater amount of thrust because of the compressed gas escaping from a smaller hole.

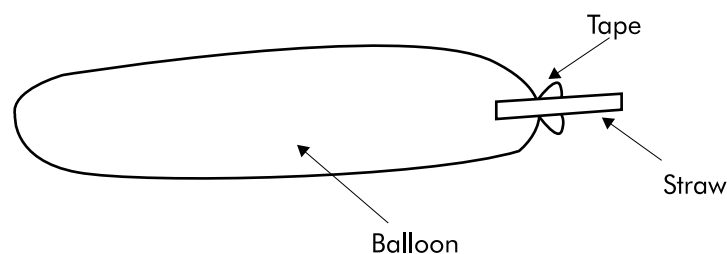

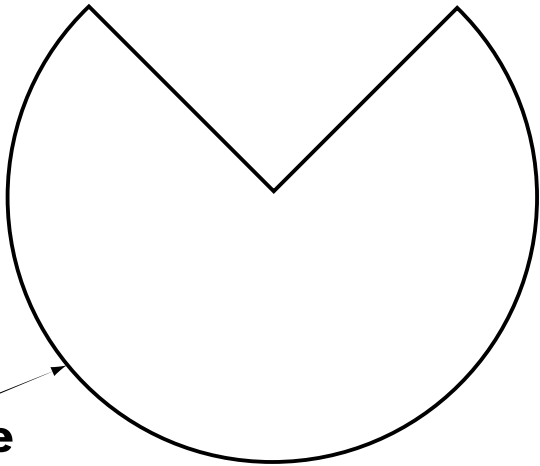

**Nose Cone**

**Jet Body**



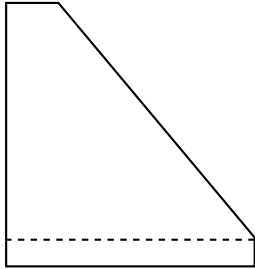

**Stabilizers**

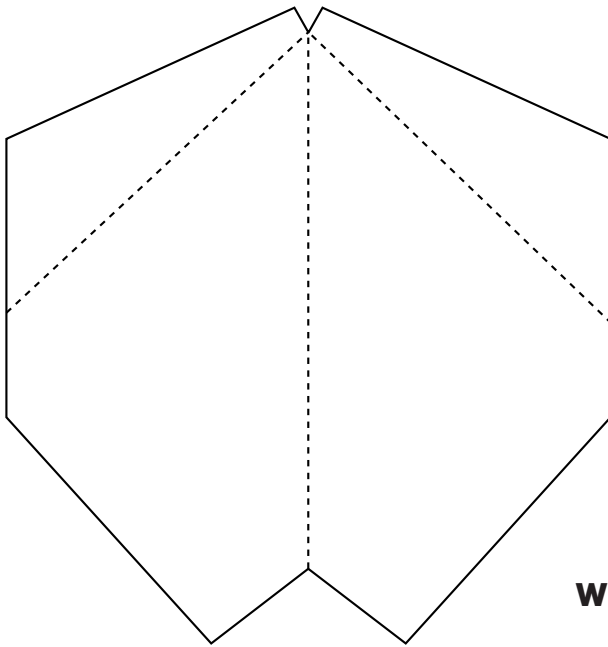
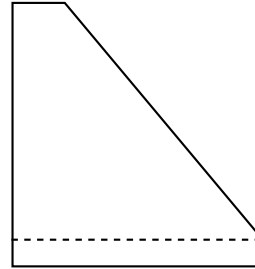

**Wings**

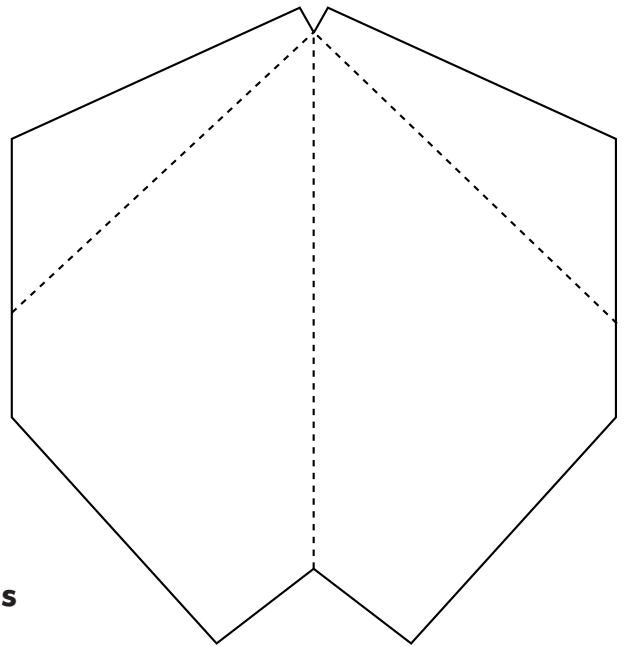

**Cut on solid lines  
Fold on dotted lines**

# Effervescent Rocket

## Description

Students construct a rocket powered by the pressure generated from an effervescent antacid tablet reacting with water. The rocket liftoff is a good example of Newton's Laws of Motion.

## Materials

1. Paper.
2. Plastic 35mm Fugi film canister\* (the canister must have an internal-sealing lid).
3. Cellophane tape.
4. Scissors.
5. Effervescent antacid tablet.
6. Paper towels.
7. Water.
8. Eye protection.
9. Optional: Rocket pattern (see page 32).

## Procedure

For best results, students should work in pairs. It will take approximately 40 to 45 minutes to complete the activity. Make samples of rockets in various stages of completion available for students to study. This will help some students visualize the construction steps.

A single sheet of paper is sufficient to make a rocket. Be sure to tell the students to plan how they are going to use the paper. Let the student decide whether to cut the paper the short or long direction to make the body tube of the rocket. This will lead to rockets of different lengths for flight comparison. Or you can use the pattern.

Make sure students tape the film canister to the rocket body, mount the canister with the lid end down, and extend the canister far enough from the paper tube to make snapping the lid easy. Some students may have difficulty in forming the cone. To make

a cone, cut out one-fourth of the circle and curl it into a cone. Cones can be any size.

## Background Information

This activity is a simple but exciting demonstration of Newton's Laws of Motion. The rocket lifts off because it is acted upon by an unbalanced force (First Law). This is the force produced when the lid blows off by the gas formed in the canister. The rocket travels upward with the force that is equal and opposite to the downward force propelling the water, gas, and lid (Third Law). The amount of force is directly proportional to the mass of water and gas expelled from the canister and how fast it accelerates (Second Law).

## Discussion

1. Does the amount of water placed in the cylinder affect how high the rocket will fly? If so, why?
2. Does the temperature of the water affect how high the rocket will fly? If so, why?
3. Does the amount of the tablet used affect how high the rocket will fly? If so, why?
4. Does the length or empty weight of the rocket affect how high the rocket will fly? If so, why?
5. How would it be possible to create a two-stage rocket?

### **Assessment**

Ask students to explain how Newton's Laws of Motion apply to this rocket. Compare the rockets for skill in construction. Rockets that use excessive paper and tape are likely to be less efficient flyers because they carry additional weight.

### **Extensions**

1. Hold an altitude contest to see which rockets fly the highest. Launch the rockets near a wall in a room with a high ceiling. Tape a tape measure to the wall. Let all students take turns measuring rocket altitudes.
2. Experiment with adding different liquids at different temperatures with the effervescent tablet, i.e. carbonated water, vinegar, or soda.
3. What geometric shapes are present in a rocket?
4. Use the discussion questions to design experiments with the rockets. Graph your results.

\* Film canisters are available from camera shops and stores where photographic processing takes place. These businesses recycle the canisters and are often willing to donate them for educational use. Be sure to obtain canisters with the internal sealing lid. These are usually white canisters. Canisters with the external lid (lid that wraps around the canister rim) will not work. These are usually black canisters.



**Cut**

**Fold**

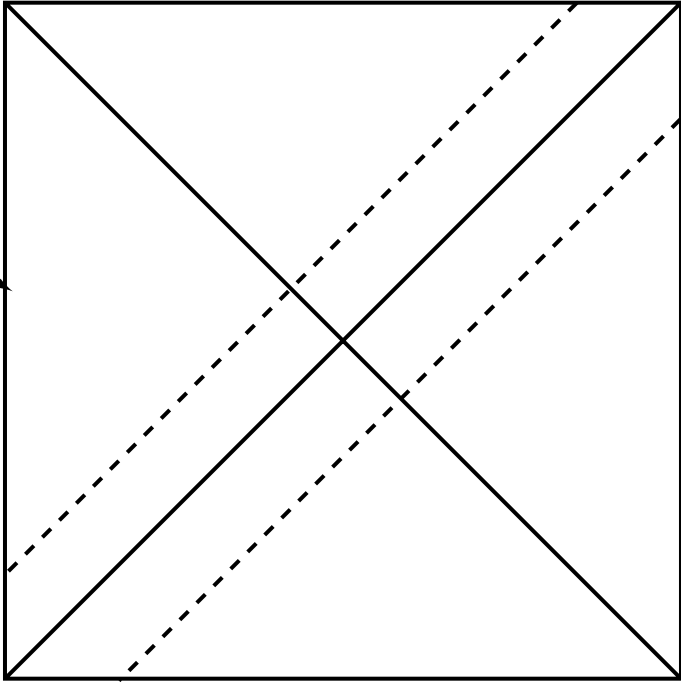

**Cut**

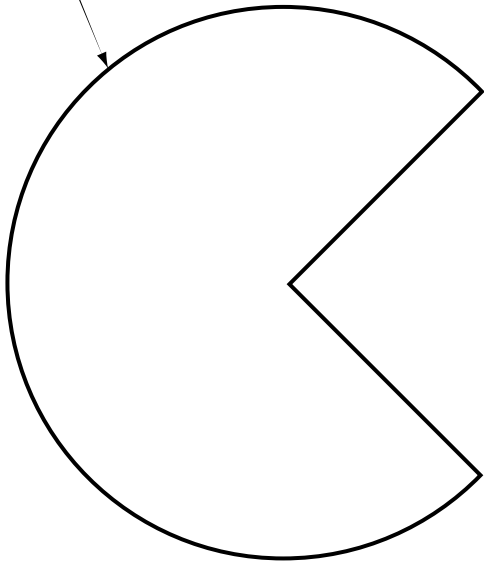

**Cut**

# Straw Rockets

## Materials

1. Pair of Scissors.
2. 1 Roll of Scotch Tape.
3. Drinking Straws of different diameters.
4. Markers or Crayons.
5. Pattern.

## Instructions

1. Cut the 3 Wings following the dark lines.
2. Color the Wings.
3. Using two 1" pieces of tape, tape each wing about 1" from the back of the straw.
4. Wrap a 3" piece of tape around the front end of the straw so the opening is taped shut.
5. Place the smaller diameter straw into the Straw Glider and blow into the smaller straw.
6. If front of glider rises, wrap some more tape near the front of the glider until the glider flies level. If the front of rocket sinks, wrap some tape around the straw just behind the wings.

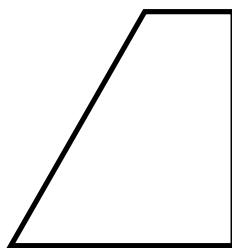
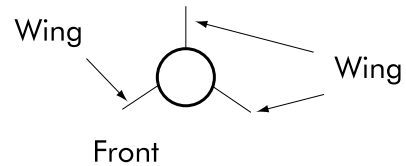
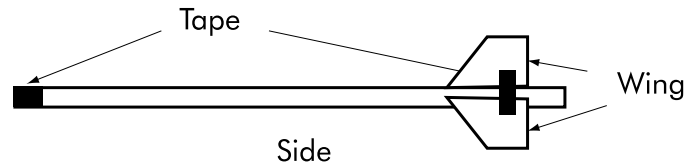

Wing

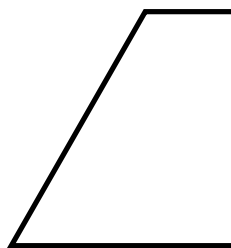

Wing

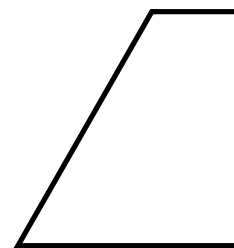

Wing

# Straw Rocket Glider

courtesy Jerry Brenden

## Materials

1. Pair of Scissors.
2. Roll of Scotch Tape.
3. Drinking Straws of different diameters.
4. Markers or Crayons.
5. Glider pattern (see page 35).

## Instructions

1. Cut the Wing, Horizontal Stabilizer, and Vertical Stabilizer following the dark lines.
2. Color the Wing, Horizontal Stabilizer, and Vertical Stabilizers.
3. Fold the Wing and Horizontal Stabilizer along the dotted lines.
4. Using two 2 to 3" pieces of tape, attach the wing to the middle of the larger diameter straw.
5. Using a 2" piece of tape, attach the Horizontal Stabilizer towards the back of the straw.
6. Using two 2" pieces of tape, attach the Vertical Stabilizer above the Horizontal Stabilizer.
7. Wrap a 3" piece of tape around the front end of the straw so the opening is taped shut.
8. Place the smaller diameter straw into the Straw Glider and blow into the smaller straw.

If the front of glider rises, wrap some more tape near the front of the glider until the glider flies level. If front of glider sinks, wrap some tape around the straw just in front of the Horizontal Stabilizer.

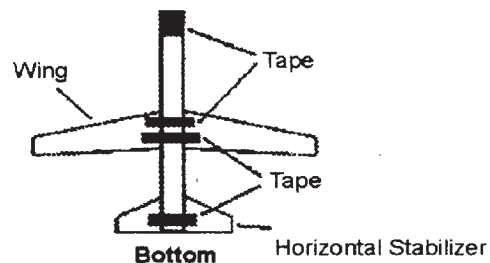
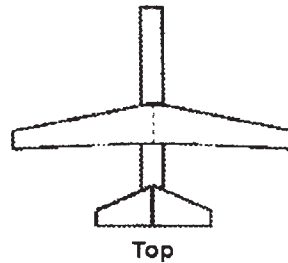
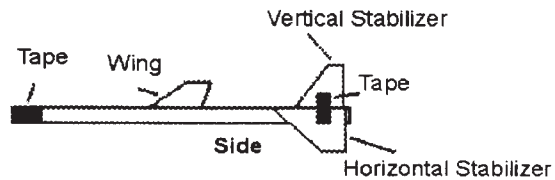

Horizontal Stabilizer

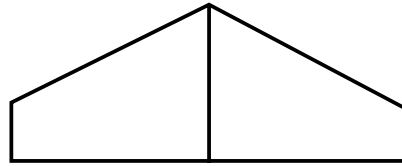

Vertical Stabilizer

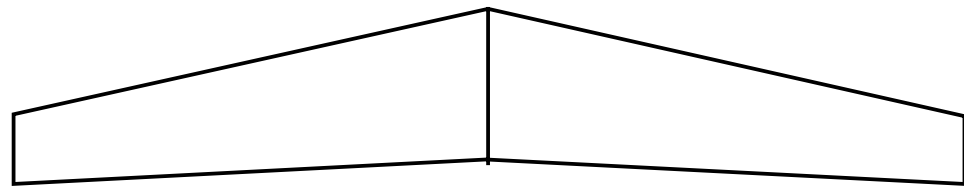
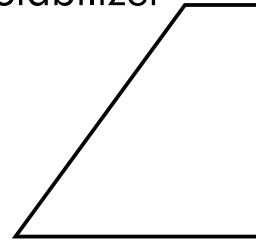

Main Wing

Students may chose either pattern, or design their own.

Horizontal Stabilizer

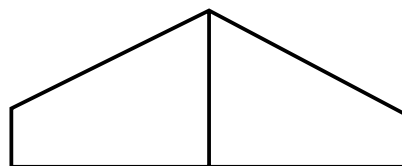

Vertical Stabilizer

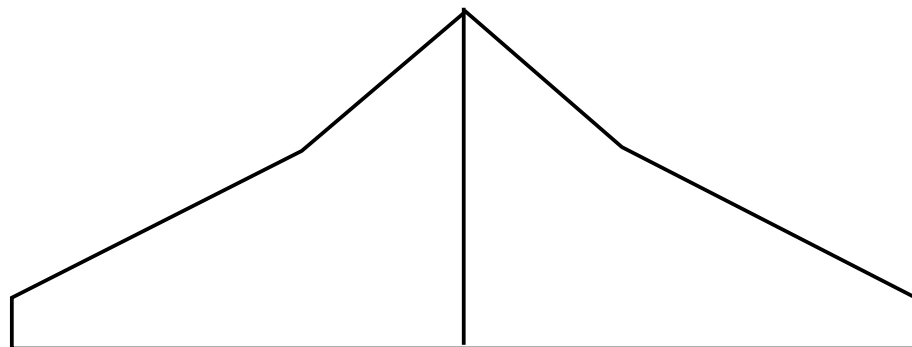
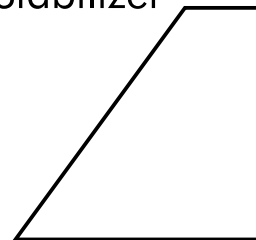

Main Wing

# Answers to Questions and Thinkers

## Carbon Dioxide

1.  $-95^{\circ}$  F.
2. It is heavier than the air around us.
3. Inflation of life rafts, fire extinguishers, compressed into dry ice, etc.
4. Displaces the oxygen.

## Sonic Cannon

1. No. Sound waves collide with air molecules and do not move them, they cause them to vibrate.
2. To let the sound waves escape in a precise direction.

Thinker 1 -

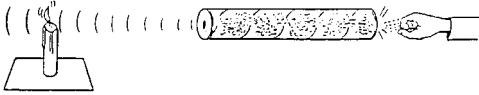

## Frontal Movement

1. Warm and cold air masses.
2. Represents the cold air which is more dense (with the salt).
3. Because it is less dense than the blue water mixture.
4. Violet (mixture of the red and blue) is half the density of the blue colored water.

Thinker 1 - Warm air masses over-ride cold air masses.

## Dewpoint

1. When dewpoint and temperature are the same, low laying clouds are formed, commonly referred to as fog.
2. Yes. Temperature is lower than freezing. At this point the water vapor in a cloud will form ice on the wings.
3. A dull surfaced can will not show condensation as well as a shiny can. A can with ridges will not permit an even distribution of condensation.

Thinker 1 - 3,700 feet above mean sea level (MSL).